

Made in Italy



EUROGUARCO

PROCESS SKID PACKAGES



INDEX

- ▶ Part I : The Company, Quality System & Certification
- ▶ Part II : Euroguarco Manufacturing & Supply
- ▶ Part III : Engineering Activities
- ▶ Part IV: Pressure Equipment
- ▶ Part V: Instrumentation Packages
- ▶ Part VI: From Engineering to Construction and Assembly of Complete Package
- ▶ Part VII: Quality Control & Testing
- ▶ Part VIII: Focus on Pig Launcher and Receiver Trap & Slug Catcher

Made in Italy



EUROGUARCO

PART I : The Company

The Company

Established in 1958 in La Spezia, our company has since gradually grown, with ties and interests with best-of-class partners and customers worldwide, in the oil & gas, energy, petrochemical, process, civil and marine industry.

Today we are proud to be known as a reliable **manufacturer and turn-key service provider** with focus on projects where pressure equipment and fluid systems are to be engineered.

In cooperation with partner-manufacturers and engineering companies, Euroguarco has performed outstanding turn-key and sub-contract works for outstanding projects worldwide, from refinery to pipeline, from seaport to civil infrastructures.

Our main business line covers:

- ▶ **Process skid packages** engineering, fabrication and supervision to installation: pig launcher & receiver, pumping station, metering station, slug catcher, system on skid, pressure vessels, storage and distribution projects, etc.
- ▶ **Valves design and production:** on-off, manual and actuated: ball, DBB, gate, globe, check, butterfly, plug type
- ▶ **Piping bulk package production and supply:** pipes, tubes, fittings, flanges, gaskets, insulation, gauges, accessories

Our services cover diverse industrial fields, such as:



Petrochemical, Oil &
Gas



Renewable Energy

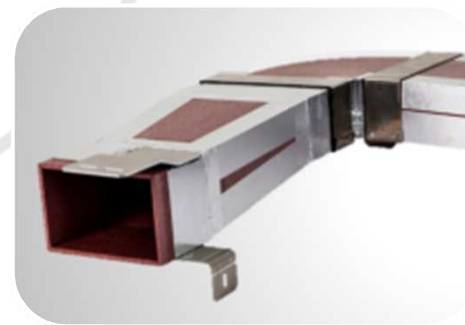

Rail



Marine

Company structure

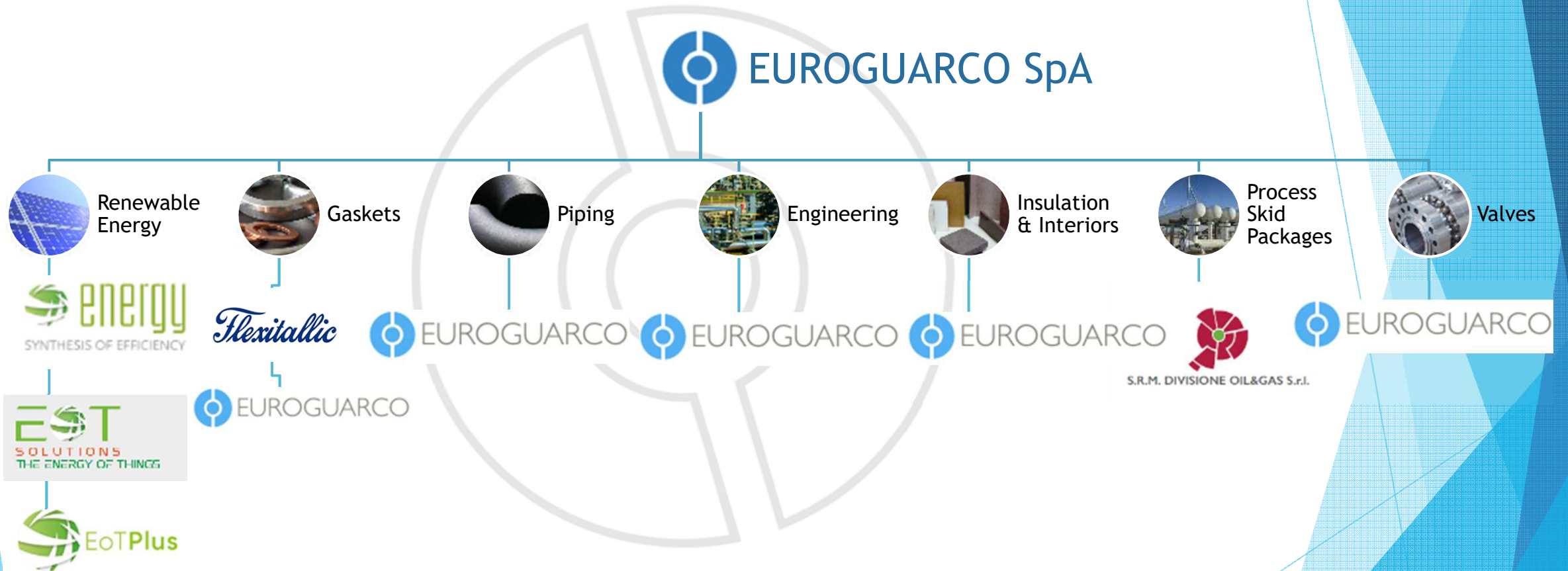

Quality System & Certification

Euroguarco works in Quality Assurance System Certificate:

- ISO 9001
- ISO/TS 29001
- API 6D License
- EN 9100 (Aeronautical Industry)
- 2014/68/UE (PED)
- ATEX

Euroguarco products have Certifications & Approvals required for use in various Industrial Sectors, among which:

- Oil & Gas (DIN-DVGW)
- Marine Industry (MED/IMO)
- Railways (EN 45545)
- Navy



Made in Italy



EUROGUARCO

PART II : Manufacturing & Supply

Manufacturing & Supply:

PROCESS SKID PACKAGES

Euroguarco Process Skid Packages provide the scope for a global solution to EPC projects, with no geographic border limitation, offering basic and detailed Engineering, Procurement, Construction and Assembly of Pressure Equipment and Process Packages supplied on skid or on design on the location, for the main industries:

- Oil& Gas
- Petrolchemical
- Chemical
- Power Generation



Manufacturing & Supply

MAIN PROCESS PACKAGES / SYSTEMS

- Oil & Gas Separation & Treatment (Trains & Packages)
- Slug catcher (Finger Type)
- Fuel Gas Conditioning / Treatment Packages
- Electrostatic Dehydrators (Desalters)
- Gas Dehydration and Regeneration Packages
- Gas Sweetening, Regeneration and Pressure Reducing Packages
- NGL Recovery Systems
- Gas Compression & water Injection Systems (Train & Packages)
- Hot Oil Systems
- Water Bath Heaters
- Direct Fired Heaters & indirect Fired Heater
- Chemical Injection Packages
- Pig traps Packages (Launching and Receiving)
- Manifolds Packages
- Flare Tips and Flare Systems.

Manufacturing & Supply

TURNKEY-ONE STOP SOLUTIONS:
Concept to Commissioning!

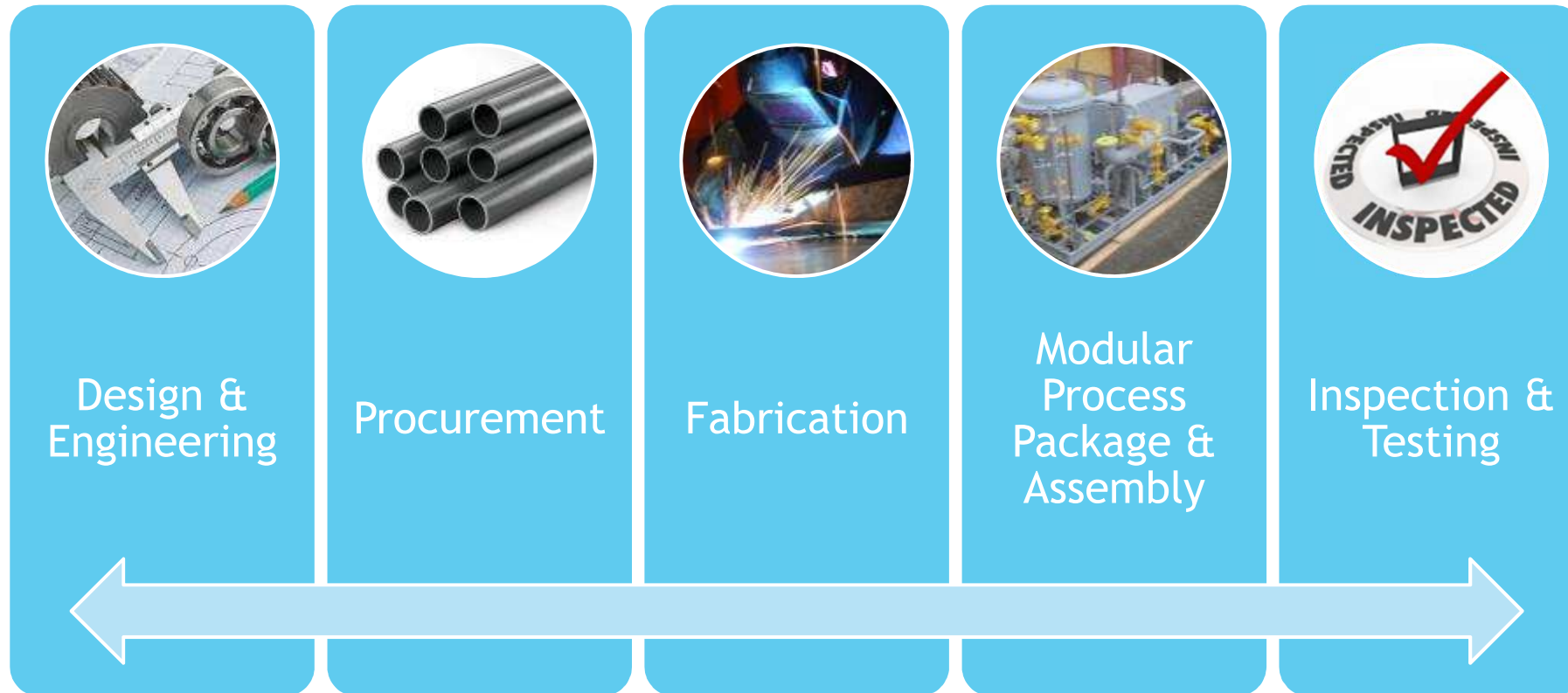

Manufacturing & Supply

EQUIPMENT - EG & partners



- ▶ Laser-cutting machine
- ▶ Sawing Machine



Manufacturing & Supply EQUIPMENT - EG & partners

- ▶ Automatic Lathe Machine



Manufacturing & Supply

EQUIPMENT - EG & partners



PRESS BENDING (JCO)

- ▶ Production range structural pipes:
- ▶ Outside Diameter 457 - 2,032 mm (18" - 80")
- ▶ Wall Thickness 9.53 - 101mm (3/8" - 4")
- ▶ Max Length 15,100 mm (49.54 ft)
- ▶ • Production range process pipes:
- ▶ Outside Diameter 457 - 1,574 mm (18" - 62")
- ▶ Wall Thickness 953 - 762 mm (3/8"- 3")
- ▶ Min Length 6,096 mm (20 ft)
- ▶ Max Length 15,100 mm (49.54 ft)

Manufacturing & Supply

EQUIPMENT - EG & partners



ROLL BENDING

- ▶ Production range:
- ▶ Min Outside Diameter 914 mm (36")
- ▶ Wall Thickness 9.53 - 127mm (3/8"- 5")
- ▶ Max Length 3,050 mm (10 ft)

Manufacturing & Supply

EQUIPMENT - EG & partners



SAW welding machine tandem type

- Min-max pipe diameter: 508 -2,006 mm
- Max pipe thickness: 65 mm
- Max pipe length: 15,000 mm
- Working speed: 0-1000mm/min
- Fast speed: 1,000-10,000 mm/min
- Wires: 4
- Video controlled welding



Oxy - Plasma cutting machines

Longitudinal max travel: 35,000 mm
Transversal max travel: 9,000 mm
Number of oxy propane torches: 8
Plasma torches: 1
Marker: 1 Fine Marker
Max thickness: 300 mm Oxy Propane; 25 mm Plasma



Beveling machine

Numerically controller axes: 3
Longitudinal travel: 16,500 mm
Vertical travel: 800 mm
Radial stroke: 250 mm
Travel speed: 0-300 mm/min
Rotation speed: 10-400rpm

Made in Italy



EUROGUARCO

PART III : Engineering Activities

1) BASIC ENGINEERING ACTIVITIES

- ▶ Conceptual Design Development
- ▶ Feasibility studies
- ▶ Basic Design Development
- ▶ H&MB, PFD and P&ID Preparation
- ▶ Design and Control Philosophy
- ▶ Functional Specifications for process Systems
- ▶ Process Data Sheets

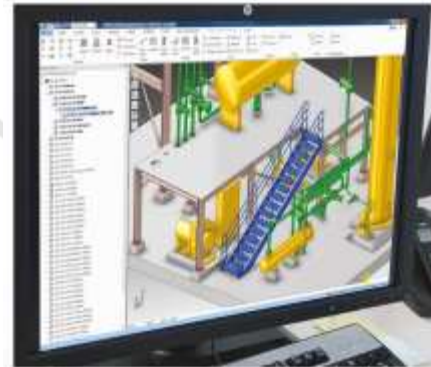

2) MAIN ENGINEERING ACTIVITIES

Process:

- ▶ AspenTech Aspen One
- ▶ AspenTech Hysys v.8
- ▶ HTRI

Detailed Engineering up to As Built:

- ▶ Piping & layout
- ▶ Instrumentation & Automation
- ▶ Technical Specification
- ▶ Bid Technical Evaluation
- ▶ Follow up supplier activities and vendor drawings
- ▶ Permitting Engineering
- ▶ Operating, Safety and Maintenance Manuals
- ▶ Commissioning, Start up and Shut down Procedures



2) MAIN ENGINEERING ACTIVITIES

Piping & layout

- ▶ Aveva PDMS
- ▶ Intergraph PDS
- ▶ Intergraph Smart Plan 3D
- ▶ Coade Caesar II
- ▶ Autodesk / AutoCad / Inventor

Civil & Structural

- ▶ Harpaceas Tekla v.20
- ▶ SAP 2000
- ▶ ROBOT

Electrical & Instrumentation

- ▶ Aveva Instrumentation
- ▶ Intergraph INTOOLS
- ▶ ZEUS 2

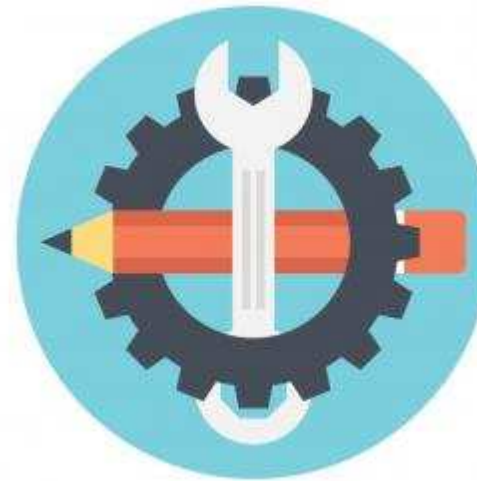

Made in Italy



EUROGUARCO

PART IV : Pressure Equipment

Pressure Equipment



- ▶ Pressure Vessel
- ▶ Slug Catcher (vessel/finger type)
- ▶ Pig Traps
- ▶ Heat Exchanger
- ▶ Gas Scrubber
- ▶ Condenser
- ▶ Boiler
- ▶ Economizer
- ▶ Sieve
- ▶ Column



Design in full accordance with customer specifications and International Standards: ASME, PED, API, TEMA, GOST, etc.

Materials of Construction: Carbon Steel, Stainless Steel and other as per customer request.

Made in Italy



EUROGUARCO

PART V : Instrumentation Packages

Instrumentation packages:



- ▶ Metering Systems (Custody and Non Custody, Orifice, Coriolis, Ultrasonic)
- ▶ Wellhead Control Panels
- ▶ Prefabricated Shelters (control Rooms, Electric Rooms, Analyzing Shelters)
- ▶ Analyzer Packages



Made in Italy



EUROGUARCO

***PART VI : From Engineering to Construction and
Assembly of Complete Packages***

From Engineering to Construction and Assembly of Complete Packages:



From Engineering to Construction and Assembly of Complete Packages:

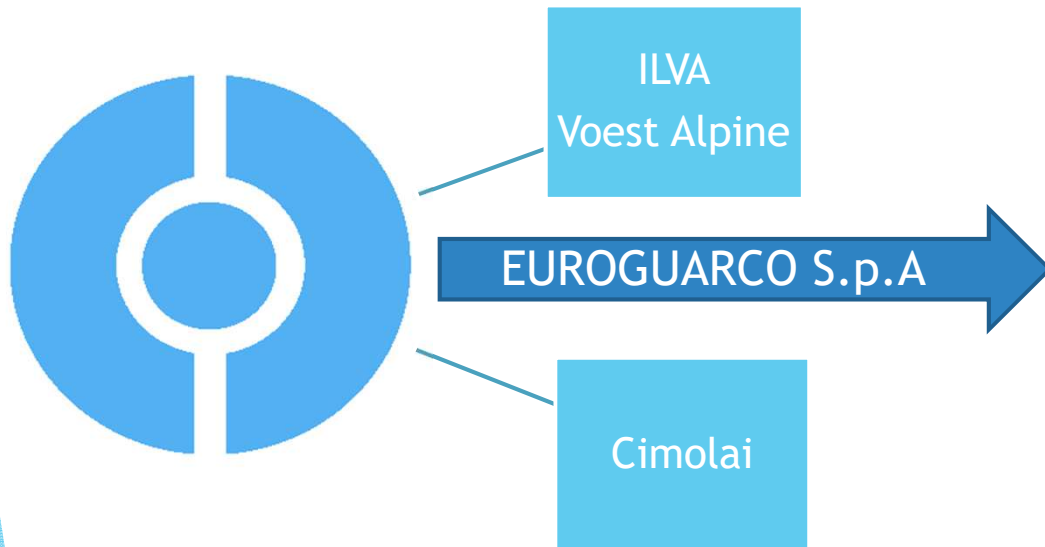

Made in Italy



EUROGUARCO

PART VII : Quality Control & Testing

Quality Control & Testing

Quality control procedure and testing are carried out in strict compliance with relevant standard or according to additional client's requirements.

Euroguarco can satisfy all testing requirements, whether in-house or from external qualified laboratories:

- ▶ i.e. Chemical Analysis: positive Material Identification Including Carbon Content if required

Special test:

- ▶ HIC & SSCC for Sour Service
- ▶ Low Temperature Test for Cryogenic Service
- ▶ Gas Test
- ▶ Any other NDE on Request
- ▶ Other Tests per Customer Request.



Made in Italy



EUROGUARCO

PART VIII : focus on Pig Traps and Slug Catcher

Focus on Pipeline Pig Traps

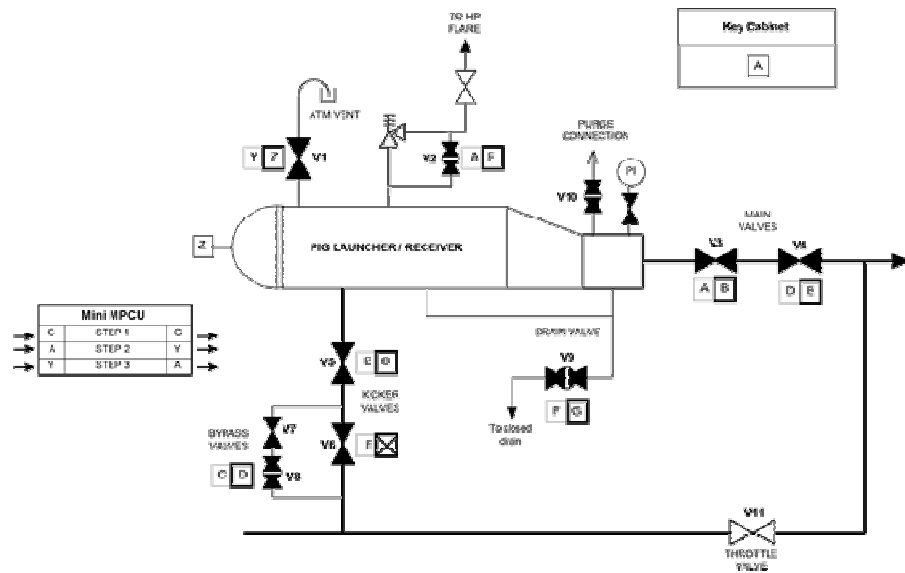

Pipeline pigs are devices that are inserted into and travel throughout the length of a pipeline driven by a product flow. They were originally developed to remove deposits that may obstruct or retard flow through a pipeline, but today are used during all phases in the life of a pipeline. Pig Traps launchers are used to slot pigs into the pipeline; Pig Traps receivers are used to catch and take off the Pigs after their use.

Today EG designs and manufactures internally the complete system for launching and receiving traps of pigs or spheres for maintenance of gas and oil transmission pipelines.

In particular our supply includes:

- ▶ Launching and receiving traps complete with quick opening closure (Q.O.C.) and safety device;
- ▶ The closure can be supplied with automatic opening device with alarm and control system;
- ▶ Traps can be skid mounted and supplied complete of pig signaler and pig handling system.

Pictures of Pig Traps



2) Pig Traps

- ▶ Size: 8" x 6" - Class 600 LBS - Material API 5L X42

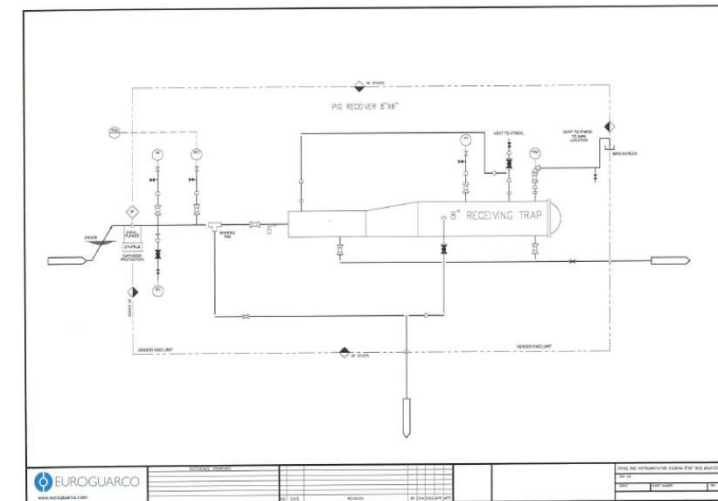
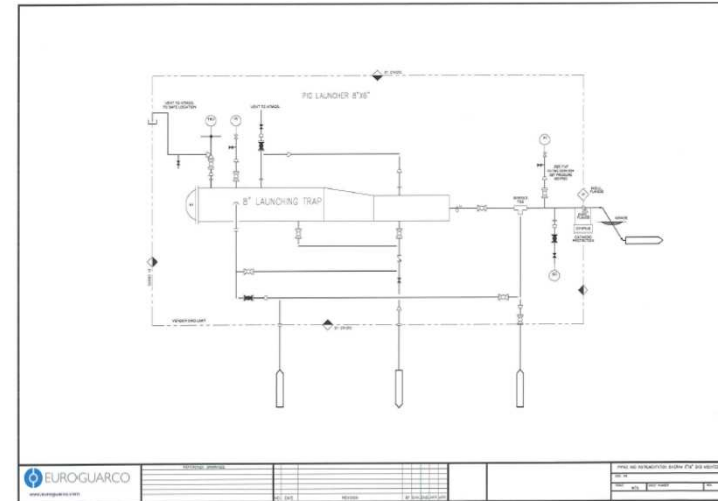
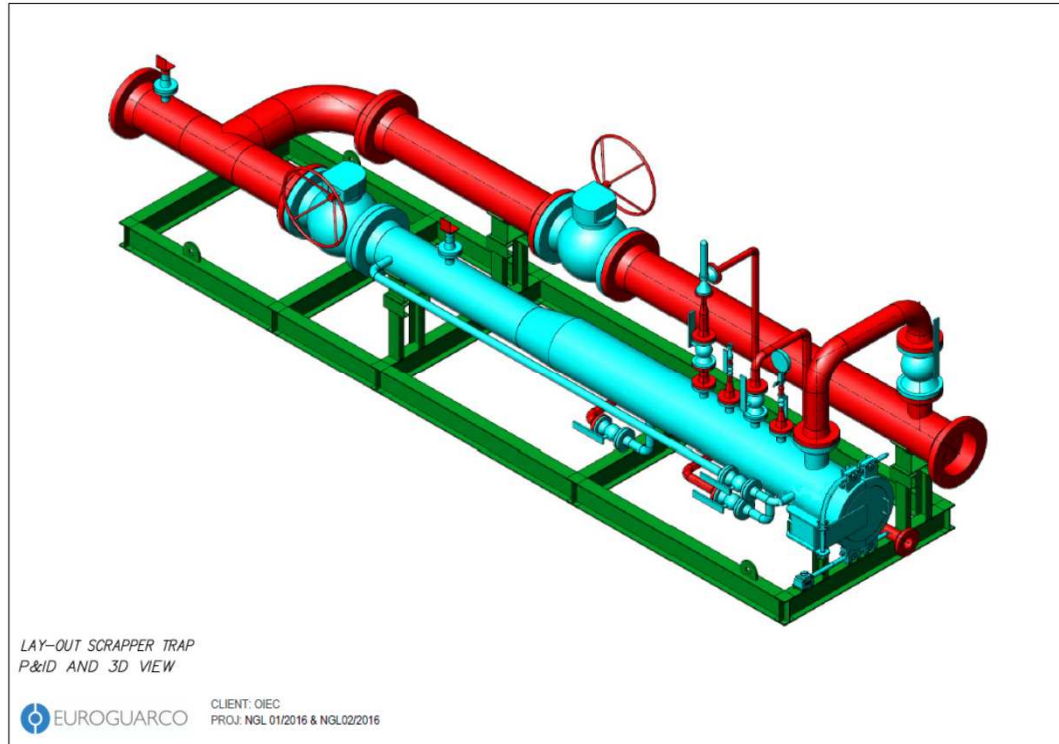

3) Pig Traps

- ▶ GATHERING SYSTEM MANIFOLD
- ▶ Size: 8" x 6" - Class 900 LBS - Material API 5L X42

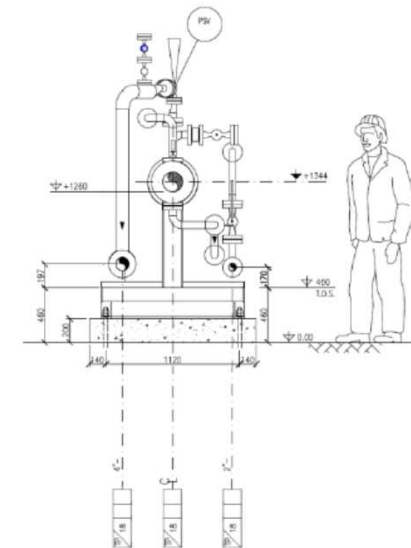
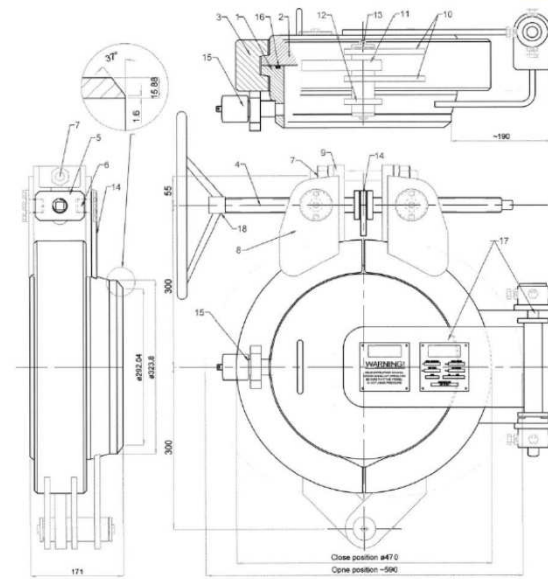
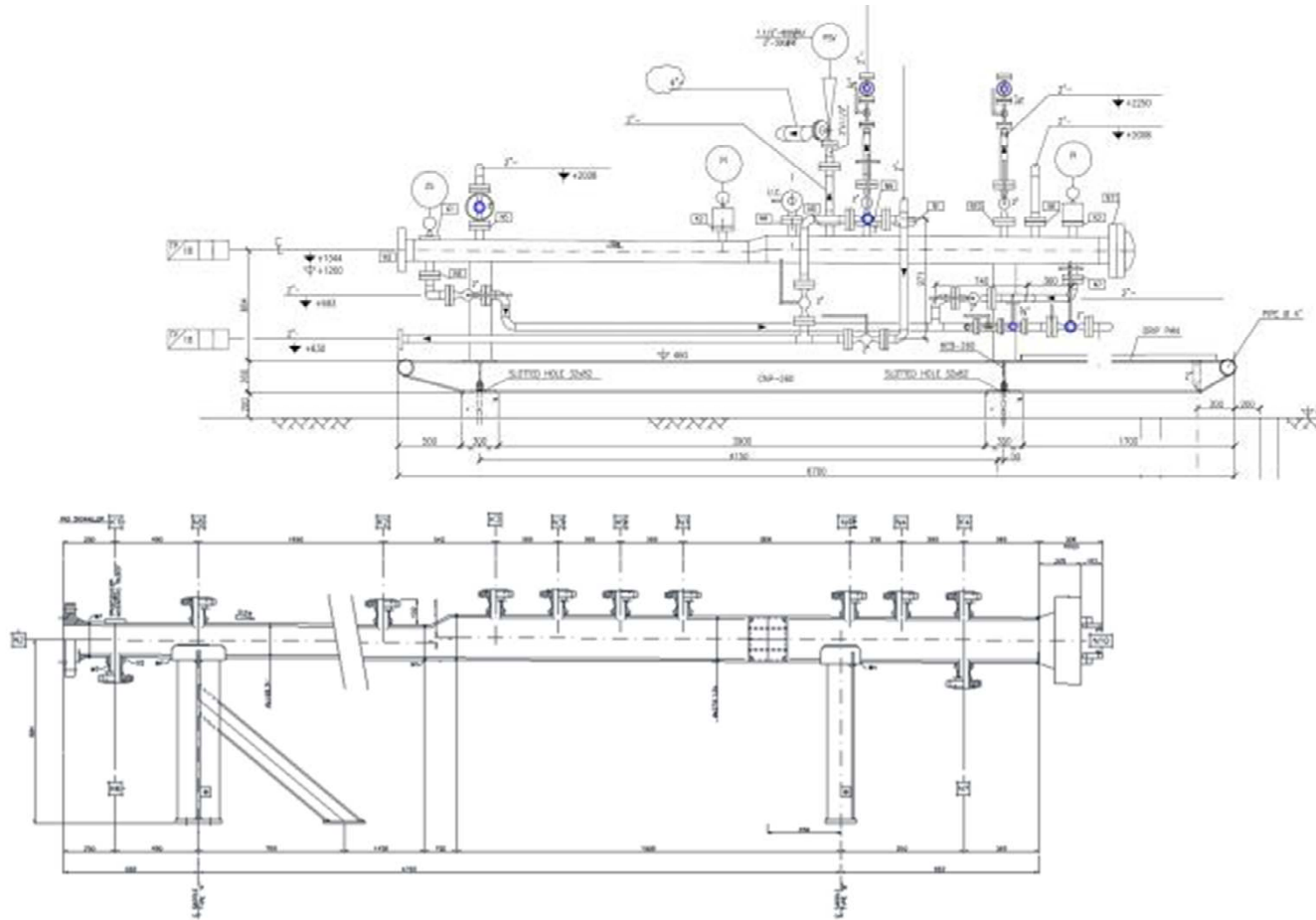

Focus on Slug Catcher

Slug Catcher is the name of a unit in the gas refinery or petroleum industry where slugs at the outlet of a pipeline are collected or caught. A slug is a large quantity of gas or liquid that exits in the pipeline.

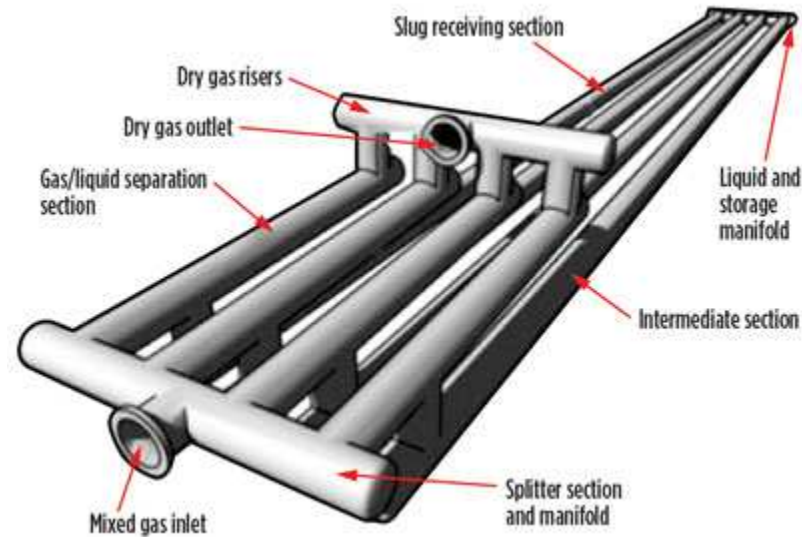

Slug catchers are designed in different forms:

- ▶ A **vessel type** slug catcher is essentially a conventional vessel. This type is simple in design and maintenance.
- ▶ A **finger type** slug catcher consists of several long pieces of pipe ('fingers'), which together form the buffer volume. The advantage of this type of slug catcher is that pipe segments are simpler to design for high pressures, which are often encountered in pipeline systems, than a large vessel.
- ▶ A **Parking Loop** slug catcher combines features of the vessel and finger types. The Gas/Liquid Separation occurs in the Vessel, while the Liquid is stored in the parking loop shaped fingers.

Pictures of Slug Catcher



Pictures of Slug Catcher



Critical Issues of Pipeline Materials Performance in Sour Environment

Ref. to Project :

Slug Catcher



EUROGUARCO SpA - Italy

www.euroguarco.com

STEEL X65 PERFORMANCE IN SOUR SERVICE

PROJECT SPECIFICATIONS:

API 5L X65 PSL2 NACE 0175/ISO 15156 - HSLA Steel

C	Si	Mn	P	S	V	Nb	Ti	Cr	Mo	Ni	Cu	CE	PCM
0.15	0.4	1.45	0.015	0.003	0.08	0.06	0.02	0.25	0.2	0.3	0.35	0.36	0.17



Microstructure:
Ferritic + Pearlitic

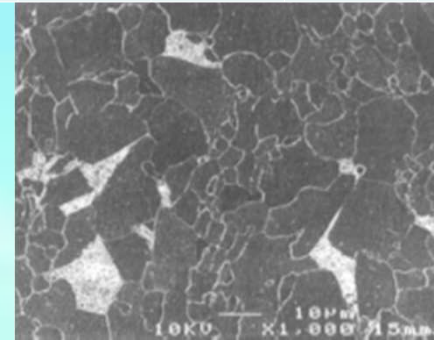

- **CE \leq 0.42** (affects stress in the steel and HAZ microstructure)
- **Good combination of mechanical properties** (toughness, strength, hardness, etc)
- **Best weldability (reliable welded structure) & formability**
- **Low sensitivity to HIC (HE), SSCC (SCC) failure**

To: EUROGUARCO SpA

Dear Cristiano,

I am honored, proud and pleased to announce that today, December 30, 2011, Ilii Servicios has successfully concluded the National Independence Bicentennial Monument "Estela de Luz". The Federal Government entrusted this state company the coordination and execution of this important monument.

In one of the most important Mexican boulevards, Paseo de la Reforma, and in a privilege zone, next to the historic Lions Gate, the entrance to Chapultepec Park, stands this piece of contemporary architecture. Its slender design and great height makes this monument worldwide unique in its kind.

México City, December 30, 2011

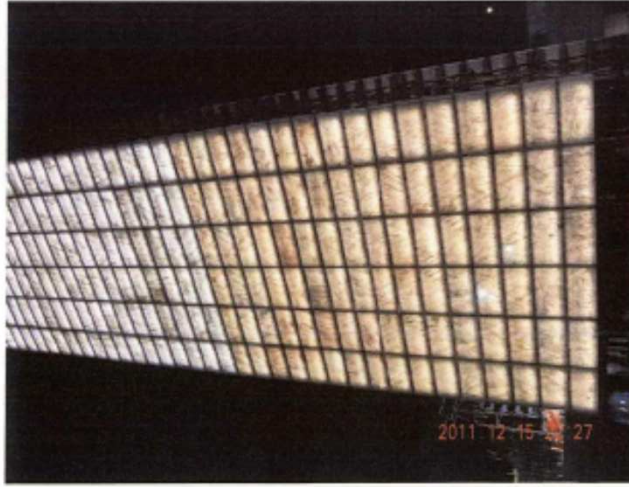

This monument is a new symbol of national identity and will become a public square, a meeting point, a recreation area, a contemporary urban and modern architectural plaza and an interactive art space for all its visitors. During the construction process, multiple aspects of structural engineering were solved: it stands in a seismic zone with very low load soil capacity, it receives significant wind pushes and suctions and it was necessary to anticipate its durability, under optimal conditions, for future generations.